

## Montageanleitung | Instructions de montage | Installation instructions

### Empfohlene Montageabstände / Distances d'installation recommandées / Recommended installation distances

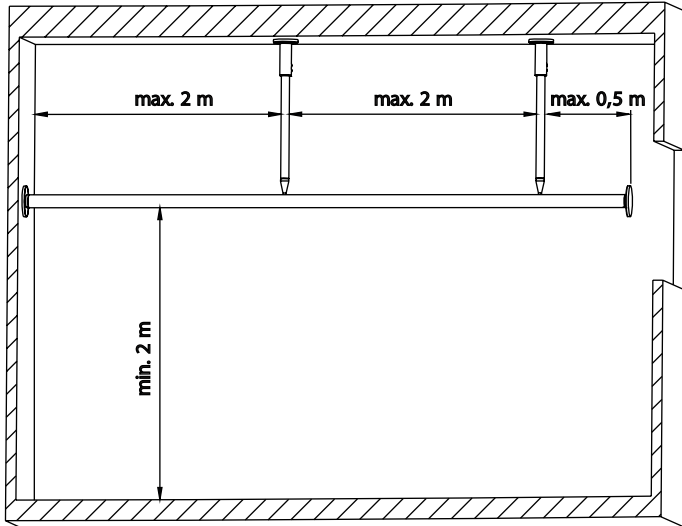

### Bitte beachten / Attention / Caution

Mitgelieferte Schrauben und Dübel sind nur für den Einsatz in Vollbaustoffe und Hohlkammersteine geeignet. Bei anderen Wänden/Decken sind Spezialdübel zu verwenden!

Les vis et chevilles livrées avec le matériel sont standards. Veuillez adapter les vis et chevilles selon la qualité des murs et plafonds.

The screws and plugs supplied with the equipment are standard. Please adjust the screws and dowels according to the quality of the walls and ceilings.

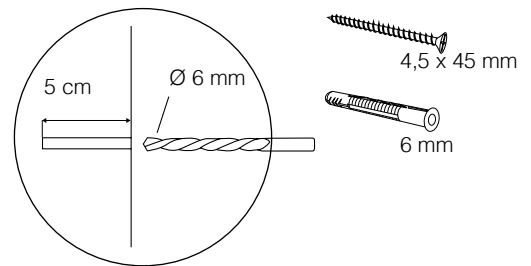

### Montage mit Profilrohr / Assemblage du tube avec les accessoires / Assembly between rail and accessories

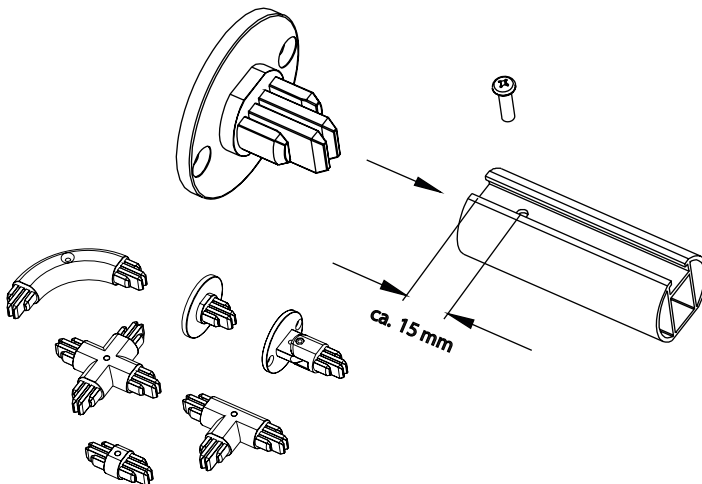

### Montage über Sturz / Montage aux linteaux / Installation across lintel

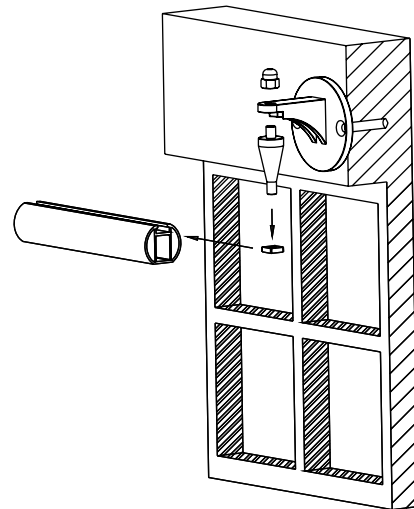

### Anschluss Wand zu Wand / Montage mur à mur / Wall to wall connection

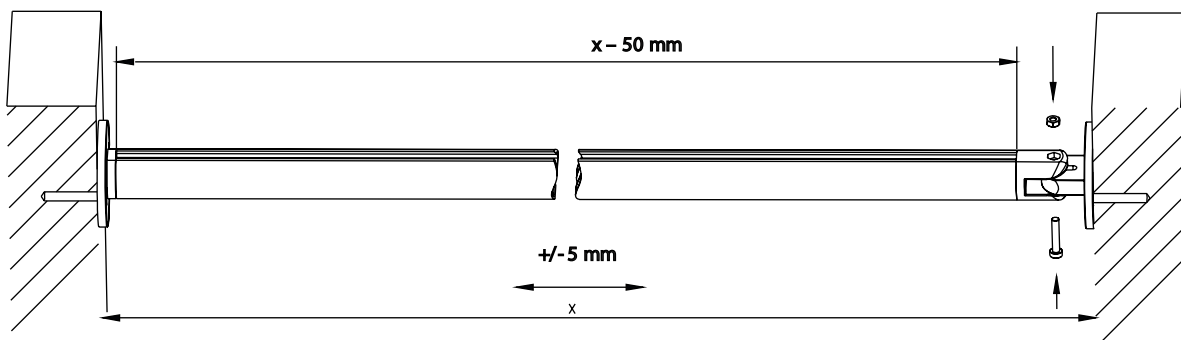

Montageanleitung | Instructions de montage | Installation instructions

Deckenmontage mit / Montage au plafond avec/ Ceiling installation with

Deckenstütze / statif plafond / ceiling column

Doppeldeckenstütze / double statif plafond / double ceiling column

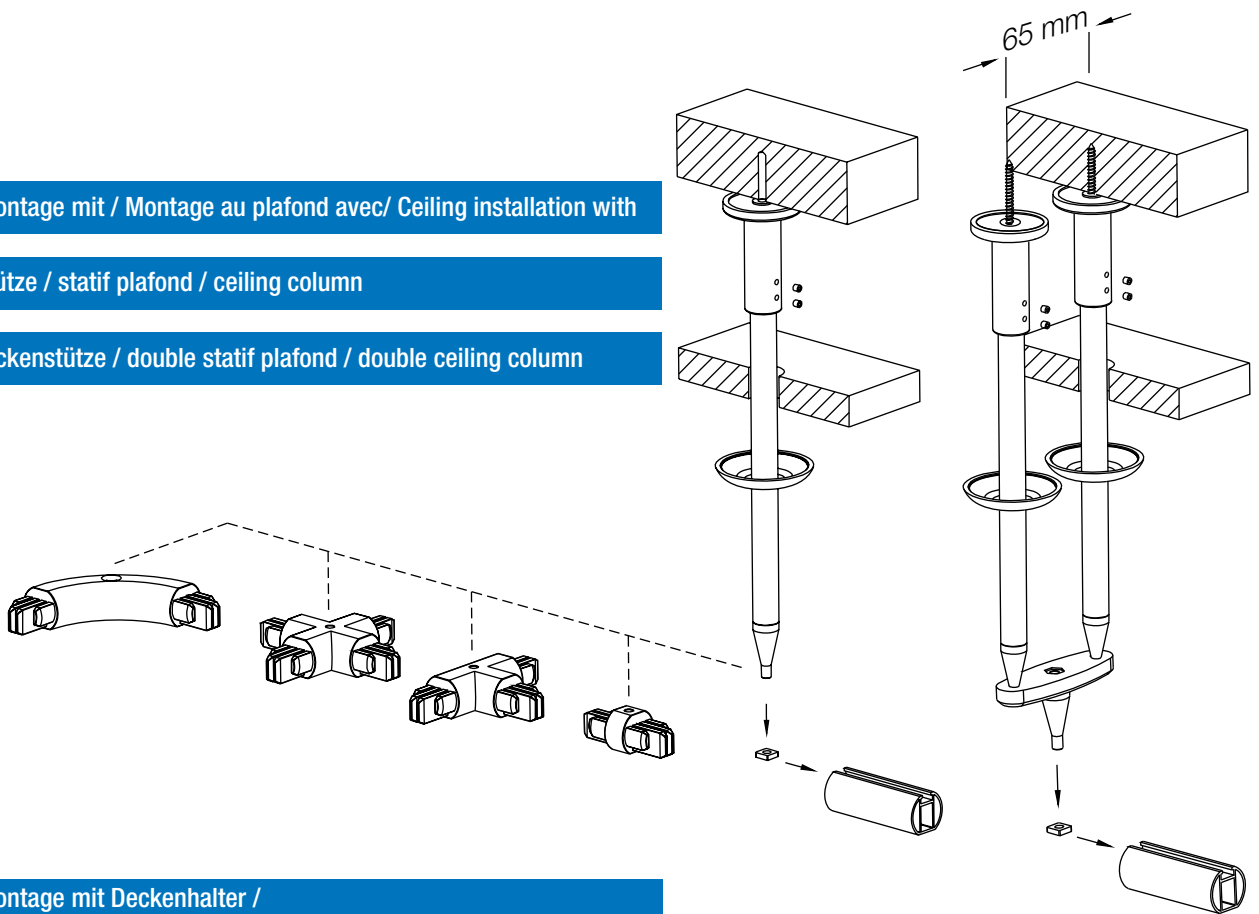

Deckenmontage mit Deckenhalter /  
Montage direct au plafond /  
Mounted directly under the ceiling

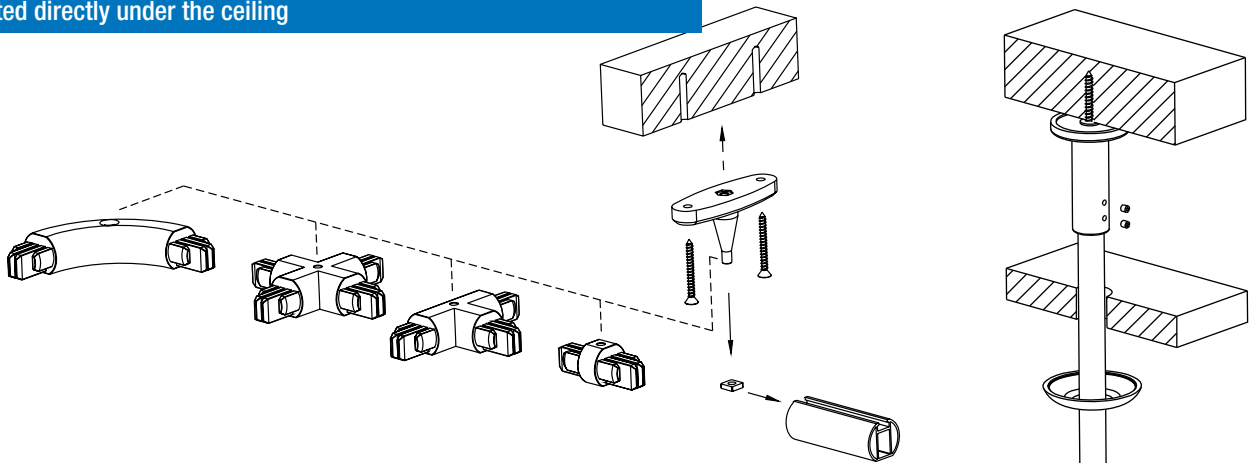

Montage mit Abzweighalter / Montage avec double accroche / Mounted with double fixing

